

PROFESSIONAL DYNO TEST ROOMS

FOR THE POWERSPORTS INDUSTRY



MOTORCYCLE • AUTOMOBILE • ATV • TRUCK • PERFORMANCE ENGINE

NOISE, HEAT & FUMES INSIDE ...

CLEAN, COOL & QUIET OUTSIDE!



®

industrial noise control, inc.

www.dynorooms.com • 800.954.1998 • www.inc-noise.com

ESSENTIAL FOR OPTIMAL DYNO TESTING

You've made a substantial investment in your dynamometer, personnel and training – to make the most of that investment and set you apart from your competition, you need to perform your dyno work in a dedicated, properly designed environment. The use of an INC Professional Dyno Room will:

- Maximize Your Dynamometer Investment
- Provide a Controlled Testing Environment
- Ensure Test & Tuning Repeatability
- Provide a Safe Workspace for Your Technicians
- Showcase Your Dynamometer Facility
- Attract & Impress Customers

INC offers a complete line of affordable, functional Dyno Test Rooms just right for any dynamometer set up. Designed and constructed of our rugged industrial duty modular acoustical panel system called Panl-Wall®, our Dyno Test Rooms are easy to install, easy to move or change with your facility and built to last. Design and performance features have been developed and tested specifically to work seamlessly with a variety of dynamometers and equipment applications to ensure a minimum of 40 decibel (dBA) sound level reduction and reliable proper ventilation.

HI-PERFORMANCE DYNO ROOMS

INC offers the most comprehensive line of Dyno Test Room packages available on the market today with pre-engineered kits specifically available for Motorcycle, ATV, Legend Car, Karts, Automotive, Engine and Endurance dynamometers.

- Isolate High Noise Levels
- Eliminate Dangerous Fumes
- Protect Your Dynamometer Equipment
- Be a Quiet Neighbor and A Safe Employer

YOU'RE IN GOOD COMPANY

INC has hundreds of Dyno Test Room Packages in use worldwide in:

- Motorcycle Dealerships
- Service Centers
- Automotive Tuning Centers
- Performance Tuning Shops
- Racing Teams
- Engine Builders
- Vehicle Manufacturers
- Performance Part OEM's
- Technical Schools & Universities



YOU **COULD** BUILD YOUR OWN DYNO ROOM... BUT HOW? AND WHY? LET **INC** DO IT FOR YOU!

A pre-engineered and manufactured Dyno Test Room from INC is much less costly and performs substantially better than any custom designed, contractor or self-built room using conventional building materials. Additionally, the long list of features and benefits you will enjoy with an INC room will set you apart from your competition by making yours a state-of-the-art, professional dyno testing facility.

DYNO ROOM FEATURES	INC DYNO ROOMS	CUSTOM CONTRACTOR BUILT
Pre-Engineered Rooms Readily Available in Kit Form	✓	NO
Guaranteed Predictable Noise reduction – 40dBA or More!	✓	NO
Guaranteed Ventilation Performance	✓	NO
Known Fixed Cost – Stays on Budget	✓	NO
Qualifies for Accelerated Depreciation and Tax Savings	✓	NO
Single Source Performance Responsibility	✓	NO
Modular Panel Construction – Easy to Erect & Change	✓	NO
Easy Two to Three-Man Assembly	✓	NO
Sound Absorbing Interior Surfaces	✓	NO
Rugged Structural & Mechanical Integrity – Built Tough!	✓	NO
Corrosion Resistant Galvanealed Construction	✓	NO
All Components Meet ASTM E-84 Class I Fire Rating	✓	NO
High Performance Acoustical Doors & Viewing Windows	✓	NO
High Performance Silenced Ventilation Systems	✓	NO
Safe, Effective Exhaust Gas Extraction & Cooling Air Flow	✓	NO
Fast, Predictable Project Completion Schedule	✓	NO
No Construction Dust – Minimal Disruptions During Assembly	✓	NO
Suitable For Outdoor Use (Optional Weather Kit Required)	✓	NO

Reduce Noise Levels by 40 Decibels and Carbon Monoxide Levels to 4 PPM!

A PERFECT FIT

Our wide variety of pre-engineered room size kits, ventilation system, and long list of optional accessories allow you to put together a total package customized just right for your dyno testing and tuning facility to get the most return on your dynamometer investment.

INC Offers Dyno Test Rooms Specifically Designed For:

- Motorcycle Dynamometers
- ATV, Legend Cars and Kart Dynamometers
- Engine Dynamometers
- Automotive (Car & Truck) Dynamometers

Although INC can design and provide custom sized and shaped rooms to meet any requirement, the most cost-effective installation will be to select one of our standard, readily available room sizes that best matches your dynamometer set-up. Choosing one of our most popular room sizes from the chart below and adding any of our long list of standard options and accessories will ensure a perfect fit with your equipment!



Most Popular INC Dyno Test Room Sizes

Dynamometer Configurations	Motorcycle/ATV				Engine			Car & Truck	
	10x15	12x15	12x18	14x16	12x12	12x20	15x20	14x30	16x30
Motorcycle – Inertia Only	•	•							
Motorcycle – with Load Retarder		•							
Motorcycle – with Extended Carriage			•						
ATV, Kart or Legend Car				•					
High Performance Engine					•	•	•		
Automotive – Car								•	
Automotive – Truck									•

Air Inlet Plenum Adds 3' to Room Length for Motorcycle/ATV and Automotive Rooms When SuperVent Ventilation System is Installed



Engine Dyno Test Room with large view picture windows

BASIC DYNO TEST ROOM KITS

Each of our standard room configurations is supplied in a kit form with all of the components required for a complete assembly including:

- Modular Acoustical Wall & Roof Panels
- Base Channel, Joiners, Trims & Flashings
- Caulking & Assembly Hardware
- High Performance Acoustical Doors
- High Performance Acoustical Windows
- Detailed Assembly Drawing Instructions

All rooms are ready to accept an INC SuperVent® ventilation system (sold separately).

MODULAR DESIGN & CONSTRUCTION

Pre-Engineered • Flexible Modular Design
Predictable Performance • Built To Last

INC Pani-Wall® Modular Acoustical Panel System is the basis of construction for our standard Dyno Test Rooms consisting of pre-engineered, Modular Acoustical Components ... *building blocks* ... that can be configured and assembled into a wide variety of structures used to control and reduce excessive noise in industrial, commercial, institutional and community environments. Although some details of construction are tailored to the specific type of dynamometer testing, all of our Dyno Test Rooms share these basic construction features:

- Factory Pre-Fabricated Modular 4" Thick Wall & Roof Panels
- Solid Steel Exterior, Perforated Steel Interior and Fully Insulated
- Sound Transmission Loss Ratings From STC-41 to STC 52
- Sound Absorption Rating NRC = 1.05
- Components of Like Size and Type are Fully Interchangeable
- One-Piece Panel Joiners Provide Leak Proof Assembly and Structural Rigidity
- Heavy Gauge Steel Base Channels, Corner Trims & Finish Flashings
- Viewing Windows are Double Glazed Acoustical Tempered Safety Glass
- All Components Fabricated From Corrosion Resistant Electro-Galvanized Steel
- All Components are Non-Flammable and Meet ASTM E-84 Class I Fire Rating

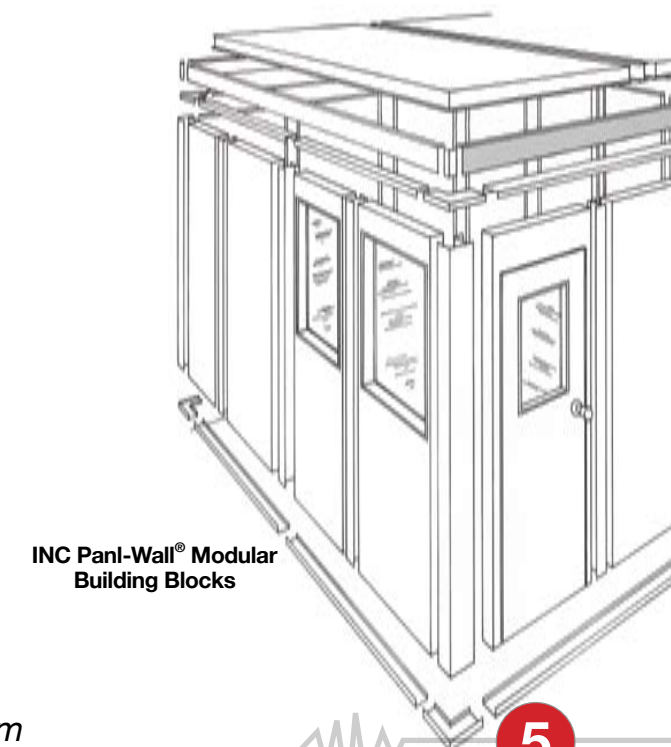
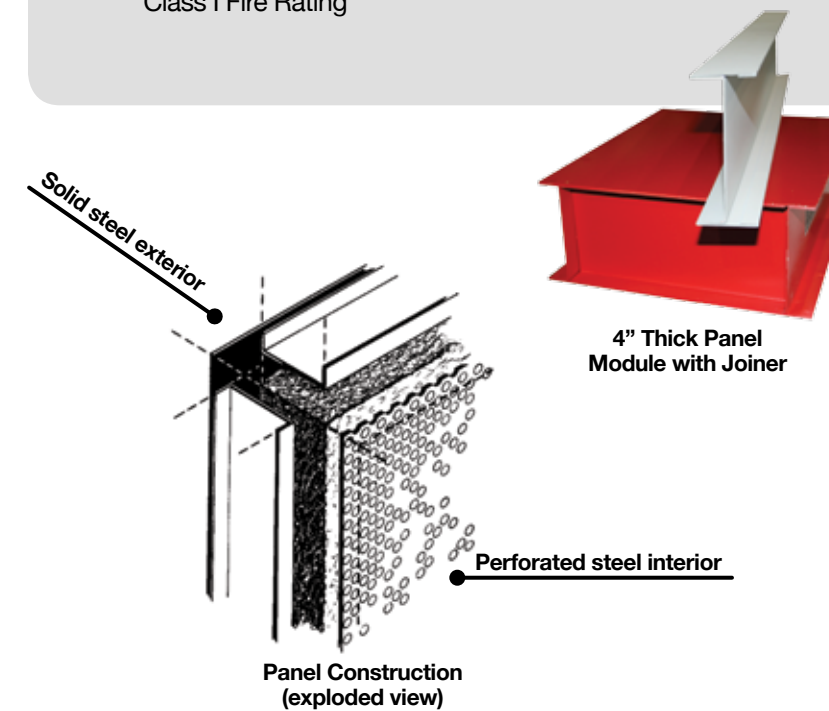

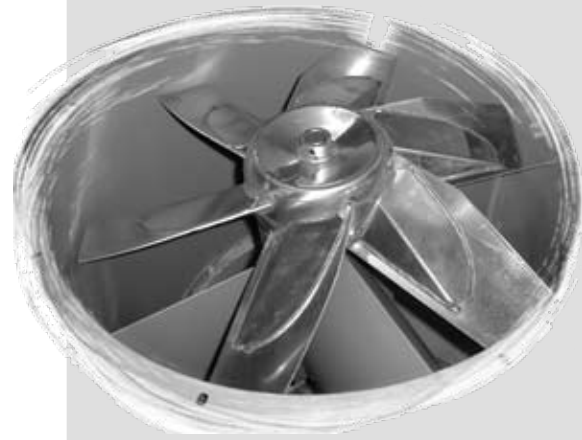

TECHNICIANS & ENGINES CAN BREATHE EASY

Of course a Dyno Test Room is only as effective as it's ventilation system, and our optional SuperVent® system guarantees to remove all heat, carbon monoxide and other combustion and exhaust gases while providing fresh air for engine consumption and operator comfort – without sacrificing any noise reduction!

Even when making long dyno runs with an eddy-current or other load applying device, such as when fuel injection mapping, our SuperVent® system with our unique flow-thru design and exhaust source capture reduces harmful carbon monoxide levels to as low as 4 ppm!

SUPERVENT® VENTILATION SYSTEM

The INC SuperVent® ventilation system is a silenced flow-thru design specifically configured to provide the high performance ventilation necessary for dynamometer testing. This requires making a complete air change inside the dyno room 8 to 10 times per minute or approximately one complete air change every 6 to 8 seconds while maintaining an inlet air velocity of approximately 2150 FPM! Our system does all this while maintaining the acoustical integrity of the Dyno Test Room... we get the heat and fumes out and keep the noise in!

The system works by drawing engine exhaust gases and heat out of the room through our unique PowerFlow® silenced exhaust stacks powered by roof mounted severe duty exhaust fans. Fresh combustion and make-up air is drawn into the room through our aerodynamically designed inlet plenum. The system is inherently self-balancing and is sized to operate under a slight negative static pressure to prevent exhaust gas leakage. For Motorcycle, ATV and Automotive Dynamometers, we also include our high temperature flexible exhaust hose kit which is required to ensure effective capture of all combustion gases.

SuperVent® Kit with parts shown for a single exhaust stack



Typical motorcycle exhaust system ductwork to exterior by customer



WHAT'S INCLUDED

Specifics of the SuperVent® system vary slightly with the type of dynamometer testing taking place as described below.

For Motorcycle and ATV Dyno Test Rooms (Up to 250 HP)

- Dual Interior Rear Stack Exhaust System
- Front Floor Mounted Fresh Air Inlet Plenum with Fixed Wall Grille
- Two 30" diameter x 5HP Roof Mounted Exhaust Fans with Mounting Transitions
- 700° Premium Grade Flexible Exhaust Hose Kit, Adapter Ends and Fittings

For Engine Dyno Test Rooms (Up to 1500 HP)

- Single Interior Stack Exhaust System
- Roof Mounted Fresh Air Inlet Plenum with Fixed Ceiling Grille
- Single Roof Mounted Exhaust Fan (Size and HP varies with room size)
- Single Carburetor Intake Drop

For Automotive Dyno Test Rooms (Up to 1500 HP)

- Dual Exterior Roof Mounted Stack Exhaust System
- Front Floor Mounted Fresh Air Inlet Plenum with Fixed Wall Grille
- Two 36" diameter x 5HP Roof Mounted Exhaust Fans with Mounting Transitions
- 700° Premium Grade Flexible Exhaust Hose Kit, Adapter Ends and Fittings

Available Options

- Space-Saver Inlet Plenums
- Low Overhead Exhaust & Inlet Configurations
- Outdoor Mounted Exhaust Fans
- Increased Vent Capacity for Higher HP Applications

Please note that our vent systems require 230/460 volt 3-phase power. 120V single phase systems are available as a purchase option for some applications. You must duct the exhaust fans out of your facility. Inlet air may be drawn from shop ambient or ducted to the exterior of your building. All ductwork beyond the dyno room is to be provided by others.

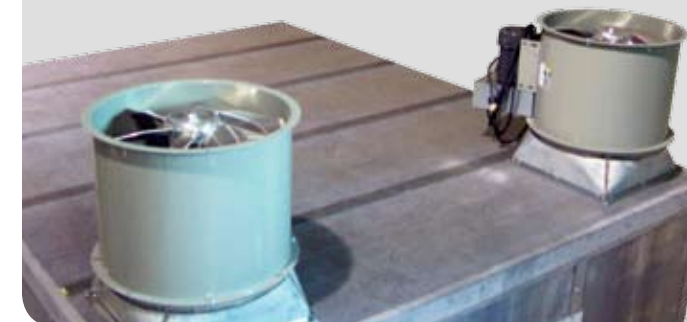

Powerful dual roof mounted exhaust fans for superior ventilation



Hi-Temp Flexible Exhaust Capture Hose shown with available adjustable stand

PowerFlow® exhaust silencer

Exhaust stack stand

Hi-Temp exhaust hose

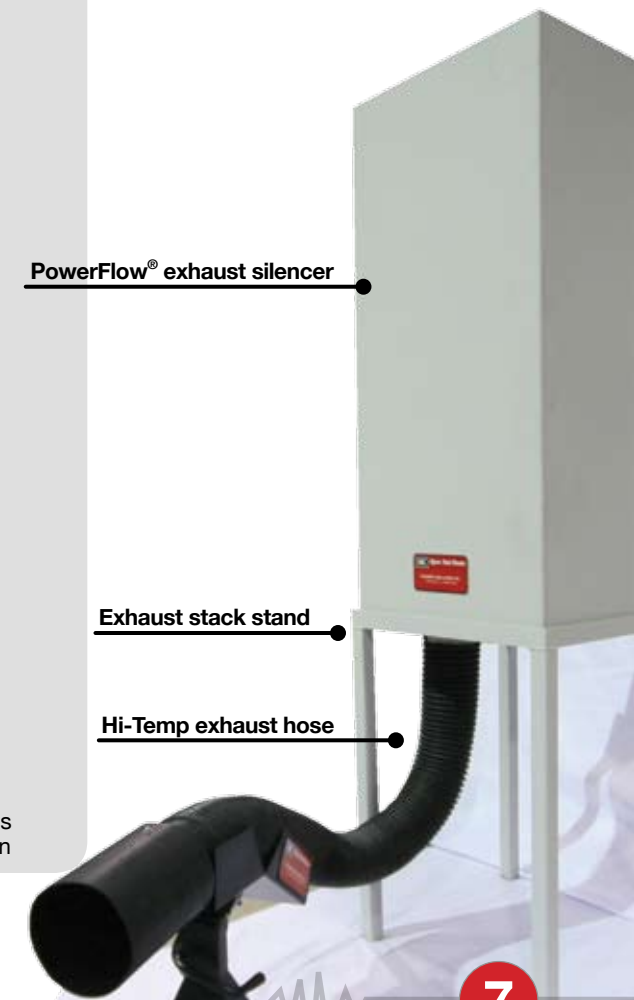

FOR MOTORCYCLE & ATV DYNAMOMETERS

Configured specifically for use with motorcycle and ATV dynamometers, we offer four standard room sizes to provide the best match and use of space for a wide variety of dynamometer set-ups. Our 12'x15' room is by far the most popular size and is fast becoming the standard in the motorcycle industry!

Standard Included Features & Specifications

- 4" Thick Panel-Wall® Construction Style STC-41
- Interior Ceiling Height of 8'-0" (adequate for both pit and floor mounted dynamometers)
- One STC-42 Entry Door 4' Wide x 7' High Single Swing
- One Viewing Window 42" Wide x 42" High (can be located conveniently around the room)

Popular Accessories & Options

- Powerful SuperVent® Ventilation System with Dual Interior Exhaust Stacks
- Larger Double Swing Entry Door 6' Wide
- Additional 42" Wide Viewing Windows
- Large Wide-View Picture Windows Available in 60" and 96" Widths
- Pre-Wired Modular Lighting & Electric Package
- Factory Prime & Finish Painting
- Heavy Duty Adjustable Exhaust Hose Stands
- Vibration Isolation Mounting Pads for Dynamometer
- Interlocking Full Rubber Floor System
- Outdoor Weather Kits

Contact INC for complete details and specifications of our accessories and options.

12'x15' Dyno Room with three windows and SuperVent®



TYPICAL LAYOUTS & DIMENSIONS FOR STANDARD ROOMS

ROOM SIZE	W	L	WINDOW	DOOR	6' DOUBLE DOOR	ADDITIONAL WINDOWS
10' x 12'	10'	12'	42" x 42"	4' x 7'	N/A	AVAILABLE
10' x 15'	10'	15'	42" x 42"	4' x 7'	N/A	AVAILABLE
12' x 15'	12'	15'	42" x 42"	4' x 7'	AVAILABLE	AVAILABLE
12' x 18'	12'	18'	42" x 42"	4' x 7'	AVAILABLE	AVAILABLE
14' x 16'	14'	16'	42" x 42"	4' x 7'	AVAILABLE	AVAILABLE

Contact INC for a complete set of Dyno Test Room plans & specifications

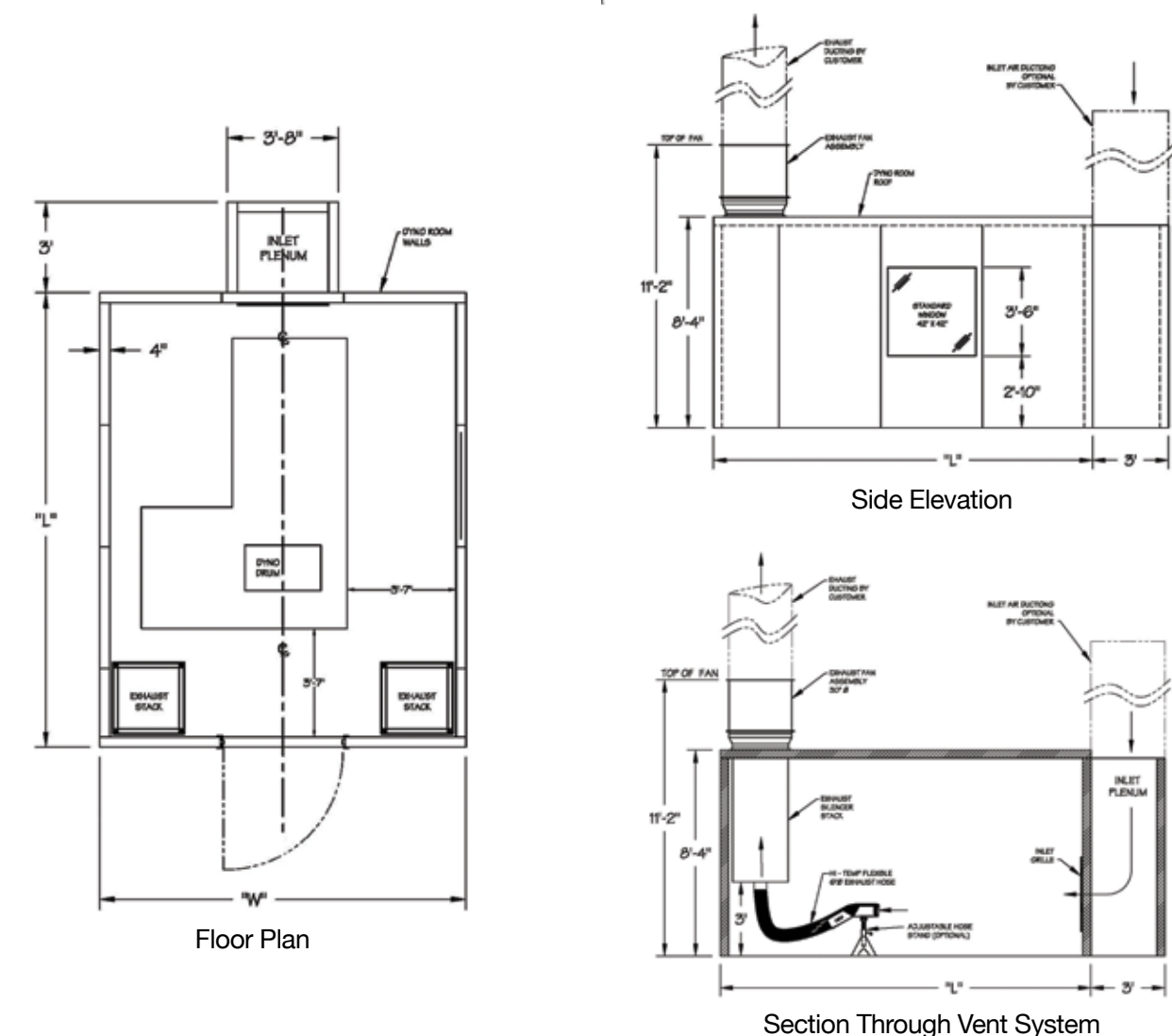



FOR HIGH PERFORMANCE ENGINE DYNAMOMETERS

Designed specifically for use with modern engine dynamometers capable of testing up to 1500 HP engines, we offer a series of six standard room sizes to provide the best match and use of space for a wide variety of dynamometer set-ups. Our 12'x20' room is the most popular size and satisfies most typical users.

Standard Included Features & Specifications

- 4" Thick Panl-Wall® Construction Style STC-52
- Interior Ceiling Height of 8'-0"
- One STC-47 Entry Door 4' Wide x 7' High Single Swing
- One Viewing Window 72" Wide x 42" High

Popular Accessories & Options

- Powerful SuperVent® Ventilation System with Single Interior Exhaust Stack
- Larger Double Swing Entry Door 6' Wide
- Additional Viewing Windows Available up to 96" Wide
- Pre-Wired Modular Lighting & Electric Package
- Factory Prime & Finish Painting
- Interlocking Full Rubber Floor System
- Operator Control Room Add-On
- Explosion Vent Relief Panels

Contact INC for complete details and specifications of our accessories and options.

WATCH THE VIDEO!

See an INC Dyno Room in Action
www.dynorooms.com

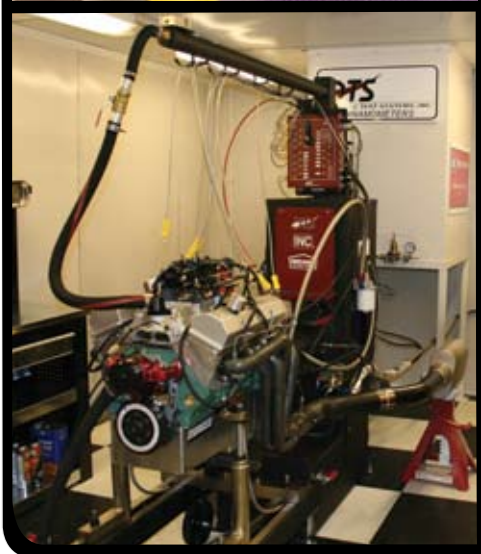

TYPICAL LAYOUTS & DIMENSIONS FOR STANDARD ROOMS

ROOM SIZE	W	L	WINDOW	DOOR	6' DOUBLE DOOR	ADDITIONAL WINDOWS	VENTILATION AIRFLOW
12' x 12'	12'	10'	42" x 42"	4' x 7'	AVAILABLE	AVAILABLE	11,000 CFM
12' x 16'	12'	16'	42" x 42"	4' x 7'	AVAILABLE	AVAILABLE	14,000 CFM
12' x 20'	12'	20'	42" x 42"	4' x 7'	AVAILABLE	AVAILABLE	16,000 CFM
15' x 15'	15'	15'	42" x 42"	4' x 7'	AVAILABLE	AVAILABLE	17,000 CFM
15' x 20'	15'	20'	42" x 42"	4' x 7'	AVAILABLE	AVAILABLE	20,000 CFM
20' x 20'	20'	20'	42" x 42"	4' x 7'	AVAILABLE	AVAILABLE	28,000 CFM

Contact INC for a complete set of Dyno Test Room plans & specifications

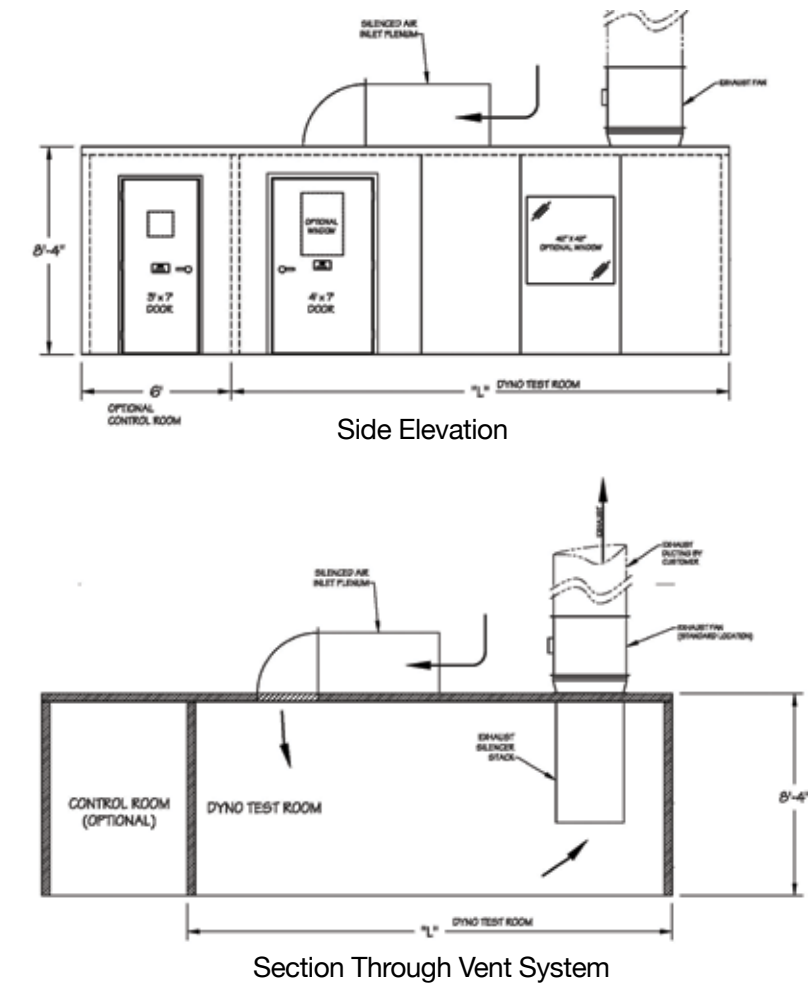
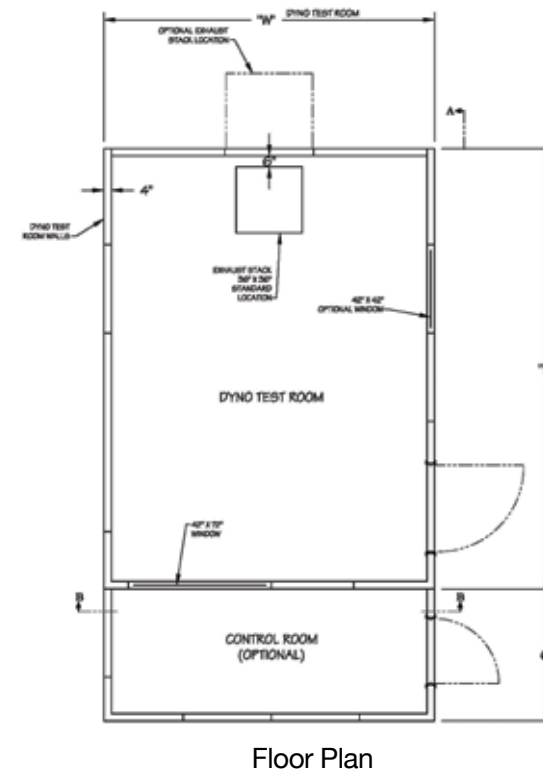

FOR AUTOMOTIVE CAR & TRUCK DYNAMOMETERS

Designed specifically for use with either above ground or pit mounted automotive dynamometers capable of testing up to 1500 HP vehicles, we offer two standard room sizes to provide the best match and use of space for a wide variety of dynamometer set-ups. Rooms are sized to accommodate front, rear and all wheel drive vehicles. It is not uncommon for us to design and provide a custom sized room to meet your specific requirements.

Standard Included Features & Specifications

- 4" Thick Panel-Wall® Construction Style STC-45/52
- Interior Ceiling Height of 9'-0" for Pit Mounted Dyno
- Interior Ceiling Height of 12'-0" for Above Ground Dyno
- One STC-47 Vehicle Entry Door 8' Wide x 8' High Double Swing
- One STC-47 Personnel Entry Door 3' Wide x 7' High Single Swing
- One Viewing Window 60" Wide x 42" High

Popular Accessories & Options

- Powerful SuperVent® Ventilation System with Dual Roof Mounted Exhaust Stacks
- Larger Double Swing Entry Door 10' Wide (recommended for truck testing)
- Space Saving Roll-Up Entry Doors (8' and 10' widths available)
- Additional Wide-View Windows Available Up To 96" Wide
- Pre-Wired Modular Lighting & Electric Package
- Factory Prime & Finish Painting
- Interlocking Full Rubber Floor System
- Explosion Vent Relief Panels
- Auxiliary Fans for Transmission and Tire Cooling

Contact INC for complete details and specifications of our accessories and options.

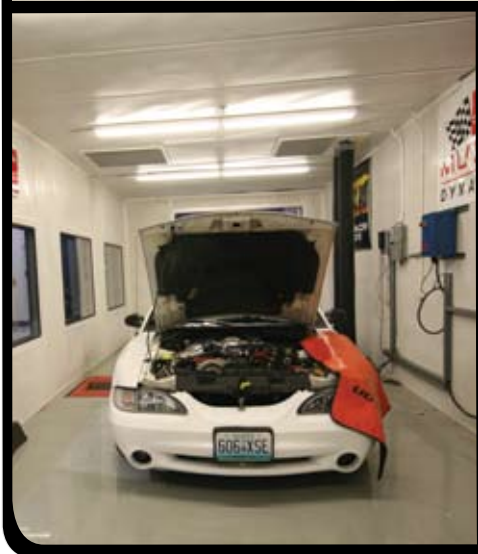

INC DYNO TEST ROOMS ARE AS EASY TO INSTALL AS ...

- 1 ANCHOR BASE CHANNEL TO YOUR SHOP FLOOR
- 2 SET AND JOIN WALL PANELS, DOOR & WINDOW PANELS
- 3 ASSEMBLE THE ROOF & TRIM AND BRING ON THE POWER!

Your INC Dyno Test Room is shipped to you in modular kit form to be assembled on site by you or your local contractor. Our modular construction is specifically designed to be installed properly and easily with no previous experience.

Assembly is very simple and can be done with a two to three-person crew using ordinary hand tools in about 3 days. We have carefully designed our system to be user installed and each room is shipped with detailed instructions and drawings... and of course, technical help is just a phone call away.

INC installation services are available upon request.

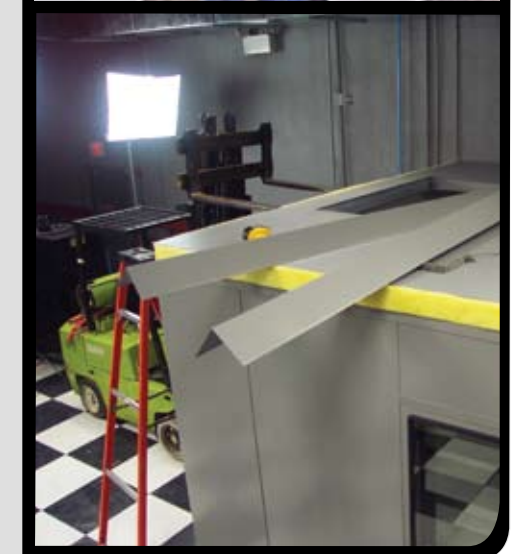

"I was able to work directly with INC to create a room that was attractive and functional. Even though our Dyno Test Room is located less than 100' from the service desk, we can still conduct business while dyno runs are taking place. Our customers can see bikes being run on the dyno and get excited about it, which sells more dyno runs and performance parts for us!"



Johnny Mancuso
Mancuso Harley-Davidson/Houston, TX

"Our Dyno Room is doing just what Carolyn at INC said it would. The room was easy to install and is very well built. And it works – the noise is low enough outside to carry on with business but still sounds great to our customers and the vent system keeps our techs happy inside. I think we got a good value with this room and we are really glad we didn't try to build one ourselves."



Langston Walker
Northshore Harley-Davidson/ Slidell, LA

"The Dyno Room supplied by INC is working great! We can stand outside the room and still have a conversation with a customer while the dyno is running. I can't imagine trying to use a dynamometer without this type of test room. It's a professional setup that helps us get the most out of our investment."

Click Baldwin
Carolina Harley-Davidson/ Gastonia, NC



"As you saw and heard, the INC room works great. Lube-Tech's INC room was assembled inside a second sheet rock room with a minimum of a 4" air gap all the way around. When I have two-cycle snowmobile engines inside running at 5500+ rpm, we can sit outside the windows and speak and hear as if nothing's going on. Everyone at Lube-Tech is satisfied with the containment afforded by this configuration."

The INC Distributor and factory people were very accommodating. They have the technology and experience to configure a single room or conjoined rooms to fit whatever needs you have. I enjoyed working with them and think you will too."

John Skuzinski
Lube-Tech
Lubrication Technologies, Inc./ St. Paul, MN

"We want to have the most technical, advanced design and accurate system available... the results are impressive! The INC test room isolates and contains the extremely high sound levels of a testing a 600+ HP engine well enough that filming of one of the other series can take place right next door. We also extract all exhaust gases and heat while completely replacing all of the air in the test room every 6 seconds with fresh outside air."



Joe St. Lawrence, President
RTM Productions/PowerBlock & HorsePower TV

"This (Harley-Davidson) program could not be possible without the support of Dynojet Research and Industrial Noise Control (INC). There are currently 8 INC Dyno Test Rooms between the two MMI campuses. The INC products provide a safe testing and training environment for our staff and students and have stood up to thousands of students that have been trained over the years. Thank you INC for your support in education."



Terry Emig
Industry Relations Manager
Motorcycle Mechanics Institute

INC COMPANY BACKGROUND

Industrial Noise Control, Inc. (INC) has been focused on providing cost-effective solutions to noise problems of all kinds since 1968. As a sales and engineering firm, our founder's vision was to combine the art and science of noise control into practical, effective solutions for industry using the most suitable products and materials available.

Today INC designs, manufactures and distributes a broad range of high performing products and structures required to solve the most common to the most unusual, complex and interesting noise control applications that occur in the industrial, commercial, architectural and environmental markets we serve.

Our modern, company owned facility in North Aurora, Illinois is located and designed specifically to support the array of manufacturing skills and operations necessary to assure our continued delivery of high quality products and systems. With the room and flexibility to accommodate both the manufacture of highly custom structures as well as higher volume standard products, INC is uniquely positioned to meet the challenges of increasing customer demands for new products, short lead times and lower costs.

INC SHOULD BE YOUR CHOICE FOR A PROFESSIONAL, COST-EFFECTIVE DYNO TEST ROOM!

With over 400 users worldwide, INC has become the clear leader in the supply of Professional Dyno Test Rooms for the PowerSports Industry. INC has the design and manufacturing expertise along with the support team and resources to continue to develop and supply the best performing, most cost-effective Dyno Test Rooms available. Our close working relationships with the industry's most notable dynamometer equipment manufacturers gives us a clear advantage in engineering our product to meet the real needs of the end user.

COMMITTED TO QUALITY AND SERVICE YOU CAN RELY ON

INC is dedicated to providing consistently high quality products, first class customer and technical support, and to keeping the commitments we make to our customers.

INC is an authorized vendor in the Harley-Davidson Tool & Equipment Program and a proud partner of Motorcycle Mechanics Institute, Ranken Technical College, North Eastern Institute of Technology and HorsePower TV produced by RTM Productions.



INC Company Headquarters & Manufacturing Facility

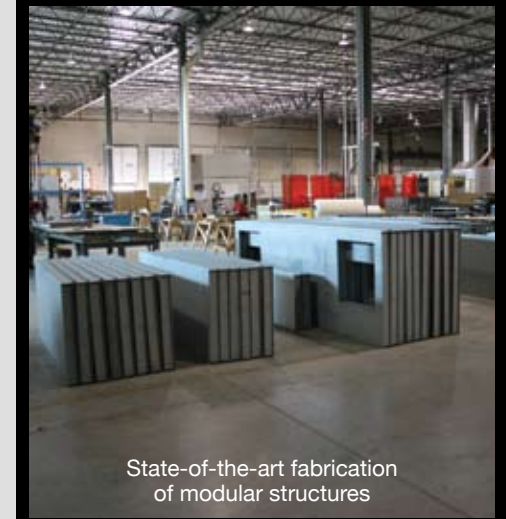
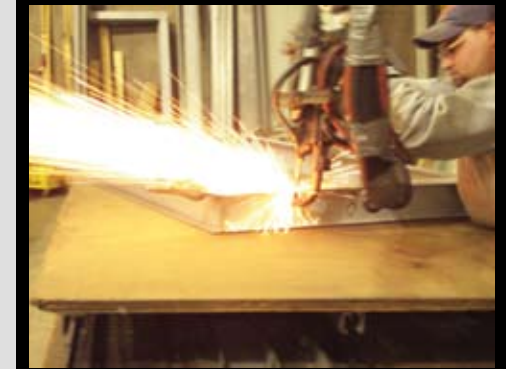

State-of-the-art fabrication of modular structures

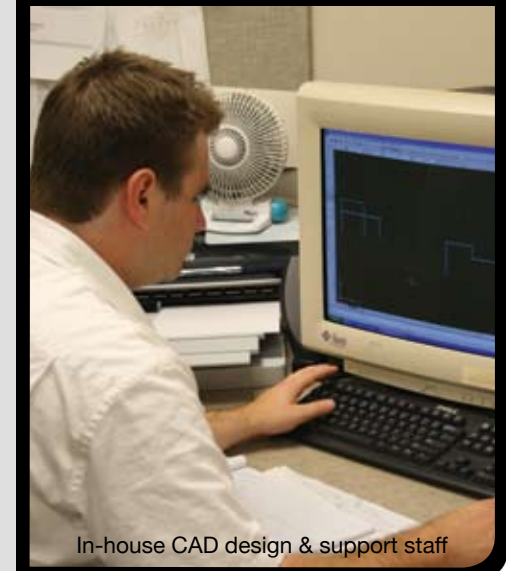

In-house CAD design & support staff



industrial noise control, inc.

401 Airport Road • North Aurora, Illinois • 60542

www.dynorooms.com • 800.954.1998 • www.inc-noise.com